

PRODUCT DESCRIPTION



RST20 TRACKED STACKER

Length 20,00 m / 65'

Max. discharge height 9,90 m / 32'4"

Weight 13,0 t / 27,660 lbs



MOBILE TRACK-MOUNTED STACKER

RST20

**SHORT SET-UP TIME.
COMPACT.
EASY TO TRANSPORT.**

APPLICATION AREAS

RST20

The Rockster RST20 mobile conveyor is the right choice for stockpiling high volume production.

It has been designed for use in combination with screening machines as well as crushers and enables impressive production capacity while reducing material handling costs.

The RST20 stacker creates large, conical and radial stockpiles, thus supporting the crushing and screening plants to significantly increase daily production capacity.

It can be ordered with tracks or wheeled, so the customer can choose the best option for the particular terrain.

The mobile conveyor RST20 hydraulically folds and is operational within 10 minutes after delivery.

TECHNICAL DETAILS

STACKER	
Length:	65' / 20,00 m
Belt width:	36" / 0,90 m
Belt specs:	EP250 - 2 ply.
Max. discharge height:	32'4" / 9,90 m (at 24 Degrees)

Capacity:	up to 350 t/h
Drive Unit:	STAGE V CAT 2.2 - 45HP / 35,5kW

FEEDBOOT	
Length:	8' / 2,45 m
Width:	6'9" / 2,06 m
Capacity:	2.0 yd ³ / 1,5 m ³

TRACKS	
Width:	16" / 0,40 m
Length:	7'11" / 2,40 m
Speed:	0.8 mph - 1,3 km/h

BENEFITS

- > BELT CLEANER
- > IMPACT BED AT FEED HOPPER
- > OPTIMAL TRANSPORT DIMENSIONS
- > FUEL-EFFICIENT SYSTEM
- > EUROPEAN HYDRAULIC COMPONENTS
- > LEVER OPERATED CONTROLS
- > SHORT SET-UP TIME

OPTIONS

- > Wireless remote control
- > 3,4m wide boot feed for extra load
- > Rubber padded tracks
- > STAGE 3 (CAT) 45HP / 35,5kW

DIMENSIONS

RST20

WORKING DIMENSIONS

Length:	67'11" / 20,70 m
Width:	7'7" / 2,30 m
Height:	30'3" / 9,20 m

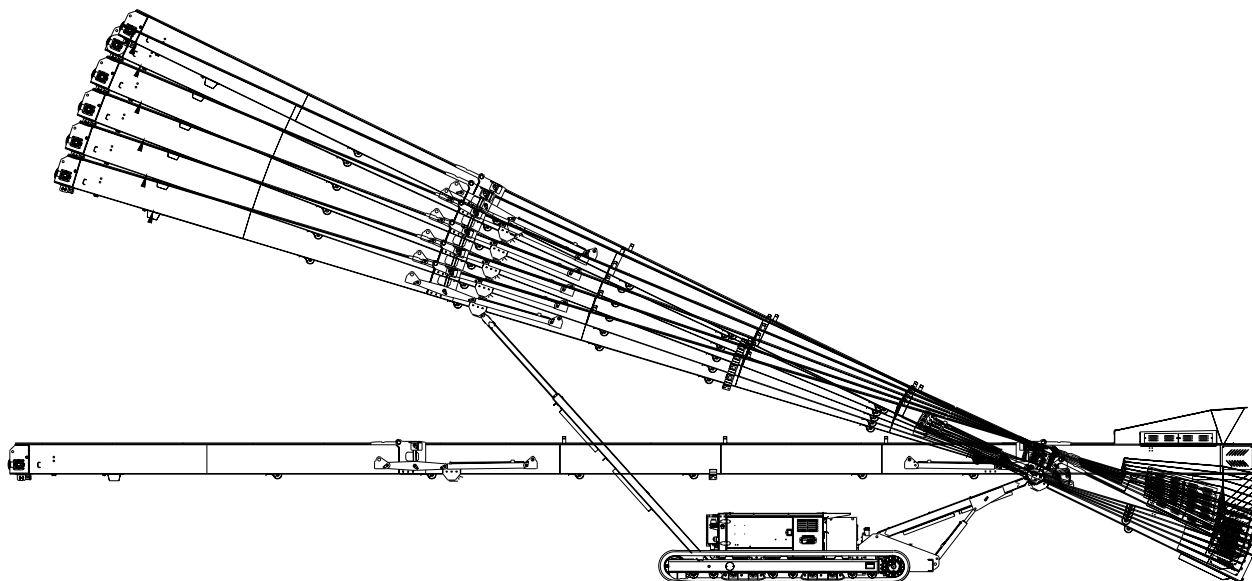

TRANSPORT DIMENSIONS

Length:	40' / 12,20 m	Weight:	28,660lbs / 13t
Width:	7'7" / 2,30 m		
Height:	8'4" / 2,54 m		

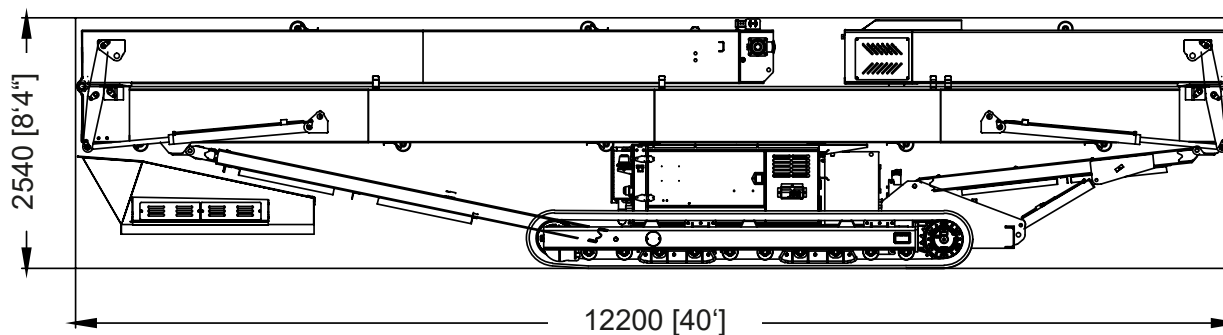

GENERAL INFORMATION



Austrian based manufacturer Rockster Austria International GmbH has a longstanding reputation and the know-how in demolition and screening industry.

The product line includes, among others, track mounted impact and jaw crushers, screening machinery and tracked stackers. "Our mobile crushers and screeners are used for profitable & economical recycling and processing of asphalt, concrete and construction waste, as well as for natural stone.

With innovations like The Original DUPLEX system or double-functional return belt, we repeatedly demonstrate our progressive approach towards improving and developing more efficient recycling & processing methods."

Rockster machines are sold in more than 50 countries worldwide. Our sales partner network guarantees the ideal on-site package of product and service in order to support and secure the daily success of our customers.



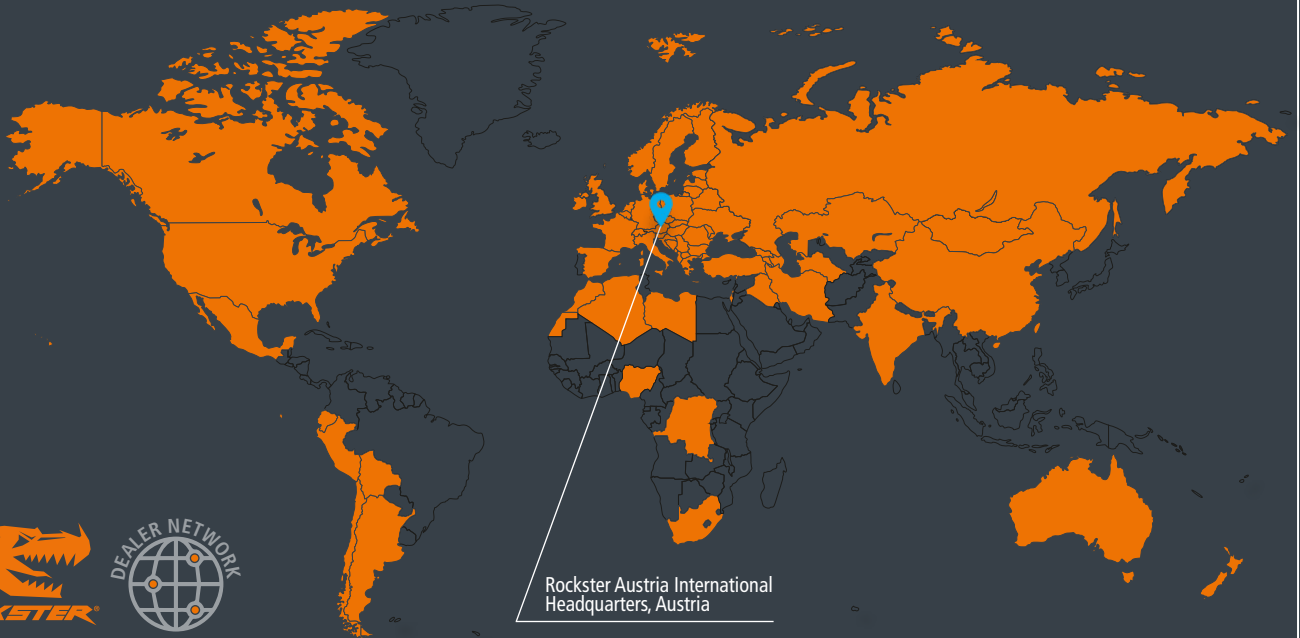

Rockster Austria International
Headquarters, Austria

SOLD IN MORE THAN 50 COUNTRIES WORLDWIDE

**COMPETENCE.
PROGRESS.
PARTNERSHIP.**

Rockster Austria International GmbH | Matzelsdorf 72, 4212 Neumarkt i.M., Austria
Tel.: +43 720 70 1212 | office@rockster.at | www.rockster.at

